



SYMPHONY

CAYENNE 5

XC sportster – LTF09: C I EN: C

TABLE OF CONTENTS

1	Introduction	35
2	Description, Technical Data, Line System	36
3	Acceleration System	40
4	Harness	40
5	Flight Techniques and Characteristics	41
6	Descent Techniques	47
7	Extreme Flight Maneuvers	50
8	Materials	53
9	Maintenance	54
10	Disposal	55
11	Maintenance-Check	56
12	Homologation	57
13	Nature and Environmentally Compatible Behavior	57
14	Closing Words	58
15	Line Schematic	59
16	Risers	60
17	Overview Glider	61
18	Test Protocoll	62

1 INTRODUCTION

Welcome to skywalk!

Congratulations on the purchase of your new CAYENNE5 and thank you for your trust in us and in our products. In this manual you will find information that will help you quickly get to know your new paraglider to ensure your fun for a long time.

At skywalk we are enthusiastic about wind sports and innovative technologies. When we founded skywalk in 2001, our goal was to make paragliders and kites that offer new solutions to set new impulses, and to provide customers with a maximum of user friendliness. Today we are one of the most successful paraglider manufacturers in the world. For this we are thankful for our curiosity about everything that flies, sails and surfs, as well as our interest in a variety of outdoor sports. It's this "big picture" view that allows us to continuously set new accents in paragliding.

We are always open for questions, comments or critique and are happy to provide you at any time with further information!

Your skywalk Team
Pure Passion for Flying



2 DESCRIPTION

With the CAYENNE5, we are redefining the sport class. Its short, crisp brake line travel turns your every impulse into immediate altitude gain and will remind you of a comp wing. The CAYENNE5 has plenty of energy in reserve to let you adjust your turning radius and bank angle without losing speed. Nothing can knock this homogenous wing off course – whether you're hunting pulsating thermals close to the slope or opening up your radius in a tight, turbulent core. The glide performance of the CAYENNE5 is world class. In cruise flight, it flies like it's on rails and its whole performance range is available to you via the smooth speed system. Because modern all-round gliders like our CHILI and TEQUILA leave no wishes unfulfilled, we decided to design the CAYENNE5 with higher performance than its predecessor. It's positioned on the upper end of the EN/LTF-C class without pushing the limit. This fifth generation CAYENNE remains loyal to its CAYENNE-series roots. Despite its direct brake line response, the new CAYENNE5's stall break is pleasantly delayed. On landing, it remains nicely controllable and the stall comes late. Thanks to its high stability, collapses are rare. Like all our gliders, the new CAYENNE5 follows the skywalk philosophy: pure passion for flying.

PILOT REQUIREMENTS

The CAYENNE5 is suitable for ambitious XC pilots up to comp pilots.

SCOPE OF DELIVERY

The CAYENNE5 comes standard with inner bag, compression strap, 2 sticker sheets, glider backpack, riser bag and manual.

JET FLAPS

Each of our gliders is equipped with skywalk's patented JET FLAP technology. Air is conducted from the bottom of the wing (pressure area) to the top of the wing (vacuum area) and is blown out there with a higher speed. The connection is established through jet shaped channels located toward the back of the wing. The addition air mass on the top of the wing delays the flow separation. The stall occurs later, the minimum flyable speed is lower, and the pilot has more reserve in the angle of attack. This is especially important in phases such as takeoff and landing. The JET FLAPS also help to improve climb performance since they allow you to circle very slowly in thermals with little danger. The glider can be flown normally as the JET FLAPS don't require any special control technique.

2 TECHNICAL DATA

Size	XXS	XS	S	M	L
Cell number	69	69	69	69	69
Area flat in m ²	21,52	22,68	24,10	26,07	27,85
Wingspan flat	11,75	12,06	12,43	12,93	13,36
Aspect ratio flat	6,41	6,41	6,41	6,41	6,41
Area projected in m	18,44	19,43	20,65	22,34	23,87
Wingspan projected	9,43	9,68	9,98	10,38	10,72
Aspect ratio projected	4,92	4,92	4,92	4,92	4,92
min. profile depth in cm	44,1	45,3	46,7	48,6	50,2
max. profile depth in cm	222,8	228,7	235,8	245,2	253,5
middle line length (without risers)	670	690	710	740	770
Line consumption in m	268,4	275,5	284,0	295,4	305,3
Weight in kg	4,8	5	5,2	5,5	5,8
Take-off weight in kg from - to	60-85	75-95	85-105	95-115	105-125
Winch certified	yes	yes	yes	yes	yes
JET FLAP technology	yes	yes	yes	yes	yes
Paramotor homologation	no	no	no	no	no
Accelerator	yes	yes	yes	yes	yes
Maximum speed bar travel in millimeters	n.s.	n.s.	160	160	160
Trimmers	no	no	no	no	no

CAUTION

THE FIRST FLIGHT MUST BE CARRIED OUT BY A QUALIFIED EXPERT. THE TYPE CERTIFICATE AND THE DATE OF THE FACTORY INSPECTION CAN BE FOUND IN THE MIDDLE CELL OF THE GLIDER. THE DATE OF THE FIRST FLIGHT AND NAME OF THE PILOT SHOULD BE ENTERED HERE. SHOULD THIS BE MISSING, ASSUME THAT THIS GLIDER IS A PROTOTYPE THAT HAS NOT BEEN TESTED.

2 LINE SYSTEM

The layout of the suspension points is designed for optimal load distribution and a long lifespan. With all considerations and calculations however, our focus is always on safety. The mix of materials used on the lines of the CAYENNE5 is an ideal combination of durability, low stretch and low drag.

The inner mainlines of the CAYENNE5 are made of high-strength Dyneema with polyester sheathing. In extreme cases, each of the main lines can withstand more than 160kg of load. To keep drag to a minimum, unsheathed Technora and Dyneema lines are used in the middle and at the top.

The skywalk CAYENNE5 has 3 A-, 3 B-, 3 C-, and 1 stabilo line.

The main-stabilo is connected with the B-riser.

The brake lines are not load-bearing and lead from the trailing edge over the main brake lines through the brake pulleys on the C-risers to the brake handles.

A marking on the main brake line indicates the position of the handle attachment. This setting should not be lengthened, for example, to provide more brake travel in extreme flight situations or during landing, nor shortened such that the glider is flown constantly with some brake on.

To provide a better overview and to make sorting easier, the lines have different colors:

→ the A1, A11 mainlines and A-risers are red

→ the B1, B11 mainlines are yellow

→ the C1, C11 mainlines are blue

→ the main brake-lines are orange

The remaining lines are unsheathed.

The lines are attached with loops to triangular shackles and secured with rubber rings.

The skywalk CAYENNE5 has 5 risers per side. These are depicted in a schematic diagram at the end of this manual.

IMPORTANT SAFETY WARNING

FLYING A PARAGLIDER REQUIRES MAXIMUM CAUTION AT ALL TIMES. WE REMIND YOU THAT YOU FLY YOUR PARAGLIDER AT YOUR OWN RISK! AS THE PILOT IT IS YOUR RESPONSIBILITY TO ENSURE THE AIRWORTHINESS OF YOUR GLIDER BEFORE EVERY FLIGHT. REMEMBER THAT MENTAL FITNESS IS ALSO A RISK FACTOR.

The skywalk CAYENNE5 may not be flown:

- outside of the minimum and maximum certified takeoff weights
- with a motor
- in rain, snow, or in extremely turbulent weather conditions, or in strong wind
- in clouds or fog (visual flight)
- with insufficient pilot experience
- if flown with more than one person
- if the canopy is wet
- at temperatures under -30°C or over 50°C
- for acrobatic flight (flight maneuvers at an angle of more than 90 degrees)

During production, the CAYENNE5 underwent carefully selected quality controls and was inspected once again before shipping. Keep in mind that a paraglider can only be flown while observing the laws of the country in which it is flown.

EN



3 ACCELERATION SYSTEM

The skywalk CAYENNE5 can be equipped with a foot-operated Acceleration-System. The acceleration system effects the A, B and C2 risers. Exact lengths and an illustration of the risers can be found at the end of the instructions. Both risers are equipped WITHOUT trimmers.

4 HARNESS

The skywalk CAYENNE5 is licensed for all certified harnesses of the GH type (harnesses without solid cross-bracing). Be aware that the relative brake travel and the agility of the glider change with the height of the attachment point.

5 FLIGHT TECHNIQUES AND CHARACTERISTICS

PREFLIGHT CHECK AND MAINTENANCE

It is important to check all paragliding equipment thoroughly before every flight to see if it has any defects. Also check the paraglider after long flights and after long storage.

Check thoroughly:

- All seams on the harness, the rescue chute attachments and the risers
- That all connecting parts, line shackles and carabiners are closed
- The brake line knots right and left, following the lines all the way up to the canopy
- All other lines from the risers to the canopy
- All line attachment points on the canopy
- The top and bottom of the wing for damage and wear and tear
- The profiles and the crossports on the inside
- If the glider is dry

CAUTION

DO NOT LAUNCH IF YOU FIND ANY DEFECTS, EVEN SMALL ONES! IF YOU FIND ANY SIGNS OF DAMAGE OR ABNORMAL WEAR AND TEAR, CONTACT YOUR FLIGHT SCHOOL OR SKYWALK DIRECTLY.



LAYING OUT THE GLIDER

If you use your paraglider for the first time we recommend that you practise some inflations and try some simple flights at a training site. This way you are able to get used to your skywalk CAYENNE5. Lay out the canopy so that the leading edge is slightly arched.

The middle of the canopy should form the deepest point of the paraglider. This way the A-lines are tensioned first in the middle whilst inflating. The paraglider inflates evenly which ensures a stable and straight take off.

The CAYENNE5 is very easy to sort due to the 3 line levels, yet sorting should always be completed carefully. All lines have to run freely without any knots and twists from the risers to the canopy.

During flight, tied or crossed over lines can often not be released or untangled! The brake-lines are lying directly on the ground, so please pay attention that they do not become entangled during launch. There shouldn't be any lines beneath the canopy during take-off. Line-overs can have fatal consequences!

TAKE-OFF

The skywalk CAYENNE5 is easy to launch. Hold the A-risers and the brake handles in your hands. For a better identification, the A-lines and covers at the A-risers are coloured red. The brake lines are coloured orange and the brake handles are black. Hold your arms slightly sideways and backwards like an extension of the A-risers. Before launching check the laid out glider.

Further check the wind direction and the airspace! Pull rapidly and the canopy of the skywalk CAYENNE5 will launch and rise above your head. The canopy will inflate fast and reliably. Keep the paraglider straight above your head and run forward.

Slow down a little as soon as the upward pull decreases. You can open any collapsed cells by pumping the affected side. Changes of directions that are necessary can be carried out now. Look and feel that the wing is properly inflated.

Don't make your final decision to accelerate or to take-off until you are absolutely sure that the wing is properly and evenly inflated.

Otherwise, stop the take-off procedure immediately! During reverse launches and in strong winds, it is possible that the paraglider surges forward and inflates faster than intended.

You can counteract this by running towards the glider. We recommend practicing this demanding launch technique on a flat slope! If you reverse launch it is advisable to only use the inside A-risers. This way the glider opens a bit more slowly and in strong winds you don't have to deal with the full pressure at once.

TURNING

The skywalk CAYENNE5 is very manoeuvrable and reacts to steering inputs directly and without delay. Simple weight shift enables you to fly very flat turns with minimal altitude loss. Combined steering technique: Weight shifting and pulling of the inside brake line allow extra tight turns. During turning you can control the speed, the curve radius and banking by additional use of the outer brake. Counter braking or releasing the brake lines can change these parameters most effectively.

CAUTION

**PULLING THE BRAKE LINES TOO FAR AND TOO FAST CAN CAUSE A STALL!
YOU CAN RECOGNIZE AN IMPENDING NEGATIVE SPIN BY THE HIGH CONTROL
LINE PRESSURE AND SLIGHT BACKWARDS FOLDING OF THE WING TIP.
IF THIS HAPPENS, RELEASE THE INSIDE BRAKE IMMEDIATELY.**

EMERGENCY STEERING

Should a brake line break or a brake handle become detached, you can still steer and land the glider with limited control using the C-risers.

ACTIVE FLYING

Active flying means flying in harmony with your paraglider. That means that instead of flying with the brakes always in the same position, you are aware of the slightest disturbances in the air and react accordingly, especially in turbulent thermals. Never let go of the brake handles, especially in turbulent conditions!

Despite your glider's high stability, you should constantly use brakes and weight shift to correct the position of the canopy in turbulence. With a light tug on the brakes you can constantly keep in contact with the canopy and feel its internal pressure. That way you can recognize and react early to a pressure drop and impending collapse. Accelerated collapses in general tend to be more impulsive and require increased attention on the part of the pilot. As you gain experience, these reactions will become instinctive.

The skywalk CAYENNE5 rarely collapses even without a pilot reaction. However, maintaining an active flying style will greatly increase your margin of safety.

Examples:

- To avoid large changes in the angle of attack, release the brakes when flying into strong updrafts and pull them when flying into downdrafts.
- When flying in turbulent air, if you feel a drop in pressure in parts of your glider, pull the brake briefly and progressively until the pressure becomes normal again. If you brake the wing too quickly and too far, you risk stalling it!

ACCELERATED FLYING

The speed bar should be secured to the harness prior to launch. To use the acceleration-system you will need to make some effort. This can affect the sitting position in the harness. Therefore we recommend an upright position in the harness. Adjust the harness before your first attempt of accelerated flight. We remind you to only fly in wind conditions that don't require constant use of the acceleration-system. To reach the maximum speed press the acceleration-system firmly until both pulleys on the A-risers touch each other. As soon as you apply the acceleration-system the angle of attack will be reduced, the speed increases, but the paraglider becomes less stable and can collapse more easily. Therefore always use the acceleration-system with adequate altitude from the ground, obstacles and other aircraft.

Avoid adjusting the speed bar too short. It is important to avoid unintentionally accelerating the glider due to a setting that is too short. Accelerated collapses are normally more impulsive and demand fast reactions.

CAUTION

- NEVER ACCELERATE IN TURBULENT AIR!**
- NEVER ACCELERATE NEAR THE GROUND!**
- NEVER LET GO THE BRAKE HANDLES!**
- NEVER BRAKE THE GLIDER SYMETRICALLY WHILE FLYING ACCELERATED!**

LANDING

The skywalk CAYENNE5 can be landed easily. Make your final approach against the wind and let the glider slow down at its own rate. Further reduce the speed by applying the brakes lightly and evenly. At about 1m above the ground you increase the angle of attack by slowing down more and eventually completely flare out the glider.

When you have reached the minimal speed apply full brake. In strong head winds, slow down carefully. When you have reached the ground safely, stall the glider warily. Avoid turning sharply before your final approach. This increases the danger of pendulum effect!



PACKING

Conscientiously packing your glider guarantees a consistently high quality. First, remove all leaves, grass, sand, etc., then sort the lines and lay them on top of the glider. Always make sure that the glider is dry and clean before you pack it.

Start with the second cell from the middle and lay them cell for cell on top of each other so that the reinforcements of the inlets are kept together. Repeat this process on the trailing edge by starting from the middle and folding together every second panel, drawing them towards the middle. After that, lay the folded panels on top of each other and press the air from the trailing to the leading edge. After doing this on both sides, turn one half onto the other and beginning from the bottom, fold the glider up towards the leading edge.

You can fold the risers in with the glider or leave them sticking out at the bottom or still attached to your harness. When packing, remember to straighten out the lines and shackles to keep them from bending. After every fold, let out the remaining air in the glider through the leading edge. Attach the compression strap around the glider loosely and place it in the nylon bag. If you prefer to use a tube, the steps are the same up the point where you turn the folded panels onto each other. Pull the straps tight and make sure that no material is caught in the zippers.

You can also pack any skywalk glider with elastic nylon wires by any other method without damaging the leading edge. Place the harness with the seat board facing up (to distribute the load better) on top of your glider and close the zippers. You will find adequate space rest of your equipment (helmet, overall, instruments, etc.) under the cover of the rucksack.

A hint to increase the life of your glider even more:
Don't pack your glider too tightly. Treat the leading edge with care despite its robustness and open up your wing a bit if you store it for a longer period of time.

WINCHTOWING

The skywalk CAYENNE5 is well suited for winch towing. Make sure that you only use certified winches and that you climb from the ground at a flat angle.

The pilot must have had proper towing instruction and must ensure that the winch operator has had proper training that includes paragliders. When launching on a winch, always fly with a lot of feeling and don't brake too much as your glider will already have an increased angle of attack. We recommend the use of a towing adapter.

FLYING WITH A MOTOR

Currently, the CAYENNE5 has no certification for flying with a motor. You can find out the current status of motor certification at any dealer or importer, or by asking skywalk directly.

6 DESCENT TECHNIQUES

This manual is not intended to be an instruction manual and skywalk highly recommends taking part in a safety training course over water. The following hints will help you to get the most out of your glider.

For all extreme maneuvers it is important:

- First to practice them under the tutelage of a certified flight instructor as part of a safety training course.
- To ensure that the airspace below you is clear before entering each maneuver.
- To maintain eye contact with your glider throughout each maneuver.



SPIRAL DIVE

The skywalk CAYENNE5 does not tend to enter a stabile spiral dive – rather, it will recover by itself if the brakes are released. You can enter a spiral dive by carefully increasing the brake pressure on the inside of a turn while shifting your weight in the same direction. If the glider doesn't bank enough and the sink rate doesn't increase, it's better to start over again rather than to keep applying brake without sensitivity. The spiral begins when the glider banks sharply to the side and enters a sharp, steep turn. You can control the bank angle and descent rate by applying or releasing the inside brake.

The spiral dive can be used to lose altitude quickly, so please consider the following:

- High sink rates and the related high G-forces lead to a high physical strain on the body that may be too much for inexperienced pilots! Approach spiral dives slowly!
- Tensing your stomach muscles during a spiral dive can be very helpful!
- If you feel dizzy or faint, exit the spiral dive immediately!
- Due to the extreme altitude loss in a spiral dive, make sure you always have enough safe reserve.
- To avoid strong surging when exiting the spiral dive, release the inside brake slowly while continuing to apply the outside brake.
- The brake line pressure in a spiral dive is substantially higher than in normal flight!

CAUTION

TO EXIT A SPIRAL WITH A HIGH SINK RATE (→ 14M/S), IT MAY BE NECESSARY TO BRAKE THE OUTSIDE HALF OF THE GLIDER AND/OR TO SHIFT YOUR WEIGHT TO THE OUTSIDE OF THE TURN. THE EXIT MAY REQUIRE SEVERAL COMPLETE ROTATIONS AND MAY CAUSE A HIGH LOSS OF ALTITUDE. FOR THIS REASON, DON'T PERFORM THIS MANEUVER AT AN ALTITUDE OF LESS THAN 200 METERS! BY THE TIME YOU REACH THIS ALTITUDE, THE MANEUVER SHOULD HAVE ALREADY BEEN COMPLETED!

BIG EARS

In contrast to the spiral dive, with big ears your forward speed is higher than your sink speed. This descent method is used to quickly leave dangerous areas in a desired horizontal direction. To collapse the wing tips, pull down both outside A-lines, which are connected to separate A-risers. The resulting collapsed wing tips will put the glider in a stable sink flight. The brake handles remain in your hands together with the outer A-risers. The glider can still be steered by braking on one side or by weight shifting. The danger of canopy disturbances in turbulent air is greatly reduced with big ears.

To exit, release the A-lines. The canopy will normally reopen by itself. You can brake a little to Speed-up the opening. It is better if you reopen one side at a time to reduce the danger of a stall.

Examples:

- If the pilot is surprised near a summit with little ground clearance by strong wind or a thundercloud, neither a B-stall nor a spiral dive can help.
- If the pilot is stuck in very strong lift, it is advisable to exit the lift band with the use of big ears and to find sinking air in which to lose altitude.

B-LINE STALL

The B-lines are pulled down symmetrically (15-20cm). Keep the brake handles in the respective hands. The airflow on top of the profile largely detaches and the paraglider descends without flying forward. Pulling hard on the B-risers allows you to decrease the area of the wing and increase your sink rate, but this also increases the risk of the wing forming a rosette to the front. If this happens, recovery from the B-stall immediately! You can exit the stall by quick and symmetric release of the B-lines. The paraglider will pitch forward and pick up speed. At no time you may use the brakes in this case! If the wing doesn't reopen you may speed up the opening process by gently braking. Subsequently: Since the CAYENNE5 has only 3 levels, the amount of energy needed for the B-stall is higher than with conventional 4 level paragliders. Generally speaking, the B-stall is a maneuver that is being performed less and less, since it subjects the glider materials to a lot of stress.

7 EXTREME FLIGHT MANEUVERS

ASYMMETRIC COLLAPSE

The CAYENNE5 is an LTF/EN-C glider and should be flown by seasoned pilots with experience in extreme conditions. Your skywalk CAYENNE5 is a very stable glider, but collapses can still happen in strong turbulence.

The inherent turn toward the collapsed side of the glider can be minimized by braking the open side. With large collapses, brake the open side carefully to avoid stalling the wing. If the collapse doesn't open despite braking and weight shifting on the open side, you can speed up the opening process by repeatedly pumping the brake on the collapsed side.

CRAVAT/ LINE OVER

This type of disturbance has never occurred during test flights with the skywalk CAYENNE5. However, it is possible in extremely turbulent air or due to a pilot error that part of the wing could get tangled in the lines. The pilot should first stabilize the glider by carefully braking the open side. Without pilot reaction, a cravat can cause a glider to enter a stable spiral dive!

To clear the cravat, there are several possibilities:

- Pumping the open side
- Pulling on the stabilo-line
- Perform a manual collapse of the affected side
- Fullstall

Should these maneuvers not succeed or if the pilot feels overwhelmed by the situation, the rescue parachute should be deployed immediately!

FRONTSTALL

The glider can be front-stalled with a strong pull on the A-risers or when encountering sudden down drafts. The leading edge collapses impulsively along its entire length. Light brake pressure can reduce oscillations around the longitudinal axis and will help to speed up the opening of the canopy.

The skywalk CAYENNE5 will recover from a front stall by itself. Should the recovery be delayed by turbulence, you can support it with light braking on both sides. Make sure that you don't over brake your glider!

PARACHUTAL STALL

The CAYENNE5 never showed a tendency to parachutal stall in the entire development phase. Despite this, it is possible to perform a parachutal stall. Gliders with porous material (UV radiation) are especially susceptible, as are those that are burdened frequently by winch tow launches. A parachutal stall can also occur when the glider is flown in rain (soaks up moisture). The glider has no forward speed and a high sink rate.

The skywalk CAYENNE5 will normally recover from a parachutal stall by itself. If this doesn't happen, the pilot can end the stable parachutal stall by pushing forward on the A-risers at the level of the line shackles or by activating the speed bar with your feet.

CAUTION

IF YOU APPLY THE BRAKES DURING A PARACHUTAL STALL, THE GLIDER WILL IMMEDIATELY ENTER A FULL STALL. NEAR THE GROUND, A STABLE PARACHUTAL STALL SHOULD NOT BE EXITED DUE TO THE RESULTING OSCILLATIONS. INSTEAD, THE PILOT SHOULD SIT UP IN HIS HARNESS AND PREPARE FOR A PARACHUTE LANDING FALL.

NEGATIVE SPIN

A paraglider enters a negative spin when one side of the wing is stalled. The canopy rotates around the vertical axis with the center of rotation located within the wingspan. The inside wing flies backwards.

There are two causes for the negative spin:

- One brake is pulled too far and too hard (e.g. when entering a spiral dive)
- One brake is pulled too hard when flying slowly (e.g. while thermal flying).

If an accidental negative spin is exited immediately, the skywalk CAYENNE5 will normally resume flight without much altitude loss. Just release the brake line that was pulled too far until the airflow is restored to the inside wing.

After a long negative spin, the canopy may surge forward on one side.

This could result in an impulsive collapse.

WINGOVERS

Alternating left and right turns as the bank angle is gradually increased. If wingover are flown high with a large bank angle, the outside wing tip may loose pressure and start to feel light. In this case, don't increase the bank angle any more as the tip could collapse impulsively.

CAUTION

NEGATIVE SPINS AND WINGOVERS OVER 90° ARE FORBIDDEN ACROBATIC MANEUVERS AND ARE NOT ALLOWED TO BE FLOWN UNDER NORMAL CONDITIONS. THE WRONG EXIT TECHNIQUE OR PILOT OVERREACTION CAN HAVE DANGEROUS CONSEQUENCES REGARDLESS OF THE TYPE OF GLIDER!

FULLSTALL

A glider enters a full stall when both brakes are pulled down too far. The glider loses forward speed and eventually collapses back behind the pilot.

CAUTION

AT THIS MOMENT IT IS IMPORTANT TO NOT LET UP ON THE BRAKES, OTHERWISE THERE IS THE DANGER THAT THE GLIDER MAY SURGE FORWARD IN FRONT OF THE PILOT AND MAY EVEN FALL BELOW THE PILOT.

The available brake line travel depends on the glider size and is about 47cm for the CAYENNE5 XXS, 52cm for size XS, 55cm for size S, 60cm for size M and 65cm for size L. However, these values are only reference points to give an idea of the useable brake travel. In turbulent air, a stall can occur much earlier or later with the application of a higher or lower amount of brake line travel.

8 MATERIALS

The skywalk CAYENNE5 is manufactured from the highest quality materials. skywalk has selected the best possible combination of materials with regard to resilience, performance and longevity. We are aware that the durability of the glider is a deciding factor in the pilot's satisfaction.

WING AND RIBS

- Upper sail: Porcher Skytex 38g
- Lower sail: Porcher Skytex 32g
- Ribs: Porcher Skytex 32g hard

The upper sail is made from highly aging resistant material to optimize the longevity of the CAYENNE5.

LINES

We have chosen a mixture of Technora and Dyneema due to its minimum stretch and high durability. These lines will never look »old« even after years of use.

- A, B, C Main lines: Liros PPSL160 / Edelrid 8000U-90
- A, B, C Middle lines: Liros DC60 / Edelrid 8000U-90
- A, B, C Top lines: Edelrid 8000U-50, 9200-30
- Brake lines: Liros DFLP200/32 / Edelrid 9200-30

RISERS

The risers are made of 12,5 mm Polyester by Cousin Freres. Stretching values, strength and stability of this material is among the highest of all webbing products available.

9 MAINTENANCE

With proper care, your skywalk glider should remain airworthy for many years. A well treated glider will be able to fly twice as many hours as a glider that after each use is stuffed without feeling back into its sack.

Always remember: your life depends on your glider!

STORAGE

Ideal is a dry, dark place with a constant temperature. Moisture is an old enemy of the durability of all paragliders. For this reason, always dry your equipment before you store it, preferably in a heated and well ventilated room, so that moisture can evaporate.

CLEANING

Any rubbing or abrasion can cause your glider to deteriorate quickly. The PU coated canopy material is dirt-repellent and in emergencies, can be cleaned easily. If you still think you need to clean your glider (e.g. of cow manure), then use a soft, damp towel or a sponge WITHOUT soap, solvent or detergent. Let your glider dry thoroughly before storing it.

REPAIR

Repairs should only be carried out by the manufacturer or by an authorized skywalk service center. Exceptions include the repair of small cuts (up to about 5 cm that don't affect a seam) that can be patched with skywalk sail tape, and the swapping out of lines. Replacement lines can be ordered directly from the skywalk homepage.

LINE REPAIRS

The main lines of the skywalk CAYENNE5 consist of a Dyneema- or Technora core and a polyester sheath. Avoid heavy loads on individual lines as excessive stretching may be irreversible. Repeating kinking of lines at the same spot reduces their strength. Visible damage to lines, even if it's only to the sheath, should be checked and possibly repaired. New lines can be ordered from the manufacturer or from an authorized skywalk service center. They will help you to replace defective lines. Before a line is replaced, the correct length has to be verified by comparing it with the corresponding line on the other side of the wing. After the replacement and before your next flight, perform a line check by kiting up the glider on the ground.

HINTS FOR MATERIAL CARE

- Avoid leaving your glider unused in the sun or lying outside in bad weather.
- Avoid exposing your glider to abrasion by dragging it over sticks and stones.
- Always fold your glider carefully and loosely and avoid sharp creases and extreme compression of the material.
- Always store the risers in the riser bag provided.
- Should the material come in contact with salt water, rinse it immediately and carefully with fresh water and make sure that it has enough time to dry in a shady location.
- If you land in a tree, never pull hard on the lines or material to free your glider. Rather, do so carefully and with patience. Once you have removed all leaves and branches from your glider, inspect the line lengths and symmetry before your next flight.
- When laying out your glider, make sure that neither material nor lines are dirty as particles caught in the fibers can shorten the lines and damage the material.
- If lines get caught on the ground, they can get stretched or torn during launching. For this reason, make sure that all lines are free and avoid stepping on them.
- Make sure that no snow, sand or stones find their way into the canopy because weight on the trailing edge of the glider can brake or even stall it. Should this happen anyway, lift up the glider by C-lines so that the air inlets are pointing down and the canopy can empty itself.
- When launching in a strong wind, part of the glider may hit the ground hard. This can lead to tears in the ribs or damage to the seams. For this reason, inspect your glider on a regular basis for this type of damage.
- After landing, don't let the glider fall to the ground on its nose as this can damage the material in the leading edge.

10 DISPOSAL

When choosing materials, skywalk places high value on environmental compatibility and the highest quality control. Should your glider someday no longer be flyable, remove all metal parts such as shackles, pulleys, etc. All remaining parts such as lines, material and risers can be turned in at a recycling center. The metallic parts can be turned in at a metals recycling center. The best solution is to send your retired skywalk glider directly to us. We will then take care of recycling it.

11 MAINTENANCE CHECK

According to LTF regulations your glider will have to undergo a maintenance check after 24 months or after 150 flight hours (according to which occurs first). According to these regulations the Two-Year-Check has to be carried out by the manufacturer, its representative or by the owner himself. The check will have to be confirmed by an official stamp (ex. Checkair label). Missing this deadline or if the check is carried out by an unauthorised company will lead the skywalk CAYENNE5 to lose any guarantee claim. We recommend not doing this check yourself. Without the proper instruments and specific knowledge the check will be insufficient. Airworthiness is therefore not guaranteed.

CAUTION

IF THE GLIDER IS SUBJECTED TO ABOVE AVERAGE WEAR AND TEAR (EXTREME FLIGHT MANEUVERS, FORBIDDEN ACROBAT FLIGHT MANEUVERS) OR IS USED FREQUENTLY IN SAND OR SALTY AIR, IT SHOULD BE INSPECTED EARLIER OR SHOULD UNDERGO AN ADDITIONAL INSPECTION!

Changes to the paraglider:

Your skywalk CAYENNE5 is manufactured within the regulated parameters of tolerance. These parameters are very narrow and must not be altered under any circumstance. Only this way the optimum balance between performance, handling and safety can be guaranteed!

CAUTION

UNAUTHORIZED CHANGES INVALIDATE THE TYPE APPROVAL AND ALL LIABILITY CLAIMS AGAINST THE MANUFACTURER ARE INVALIDATED.

12 HOMOLOGATION

The CAYENNE5 is certified to LTF 09 and EN926-1, EN926-2 in the category C. The CAYENNE5 is defined as a lightweight sport aircraft with an empty weight of less than 120kg in the paraglider category. The many homologation tests are the last hurdle in the development of a skywalk paraglider. The homologation test flights only take place when the test team is completely happy with the glider development. We remark that the certification results will differ during flight in thermals or turbulent air. The homologation informs solely regarding the paraglider performance during extreme-flight-maneuvres performed in stable air conditions. These extreme-flight-maneuvres during the homologation process should thus not be over-valued. Remember that certification maneuvers were carried out with a harness in the group GH with a carabiner distance (middle to middle) of 42-46 cm. If another harness is used, the glider may display flight characteristics that differ from those in the description.

13 NATURE AND ENVIRONMENTALLY COMPATIBLE BEHAVIOR

We have taken the first step towards ecological awareness with our nature-friendly sport. Especially with our mountain climbers who prefer to climb to the launch site. Nevertheless, we plan on continuing in the same vein. This means specifically: clean up your trash, stay on marked trails and don't cause unnecessary noise. Please help to maintain the balance of nature and to respect animals in their territory.

14 CLOSING WORDS

The skywalk CAYENNE5 is at the pinnacle of paraglider development in the market for sport class gliders and shows what is possible regarding performance, safety and innovation. It cost us a lot of time to develop this glider, but it was also a lot of fun. In this development we recognize the challenge of making the right product for every area and individual taste. We are pleased if you notice this during your first flight and if you feel a certain unity with your glider from the very beginning.

The CAYENNE5 will provide you with plenty of joy over many years if you treat it and care for it properly. Respect for the demands and dangers of our sport are essential for successful and beautiful flights. Even the safest paraglider can be dangerous due to misjudgments of meteorological conditions or pilot error.

Always remember that flying sports are potentially risky and that you are responsible for your own safety. We advise you to fly carefully and to respect laws in the interest of our sport, because every pilot always flies at his or her own risk!

WE WISH YOU A LOT OF FUN WITH YOUR NEW GLIDER AND ALWAYS HAPPY LANDINGS!!

Your skywalk Team

SKYWALK

GmbH & Co. KG

WINDECKSTR. 4
83250 MARQUARTSTEIN
GERMANY

Fon: +49 (0) 8641 - 69 48 40
Fax: +49 (0) 8641 - 69 48 11

www.skywalk.info
info@skywalk.info

15 LINE SCHEMATIC

This line schematic is only for illustration purposes. Schematics for other sizes are available through your flight school, importer or skywalk.

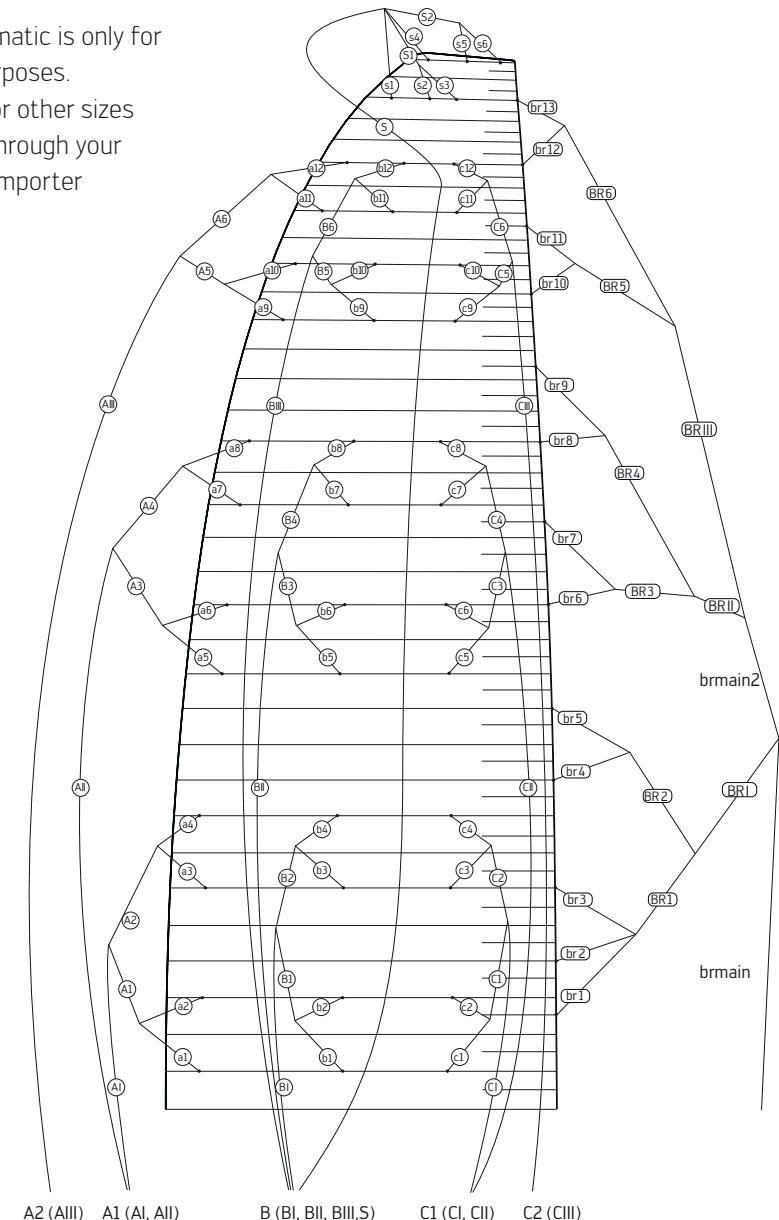

16 RISERS

CAYENNE5

Size S,M,L

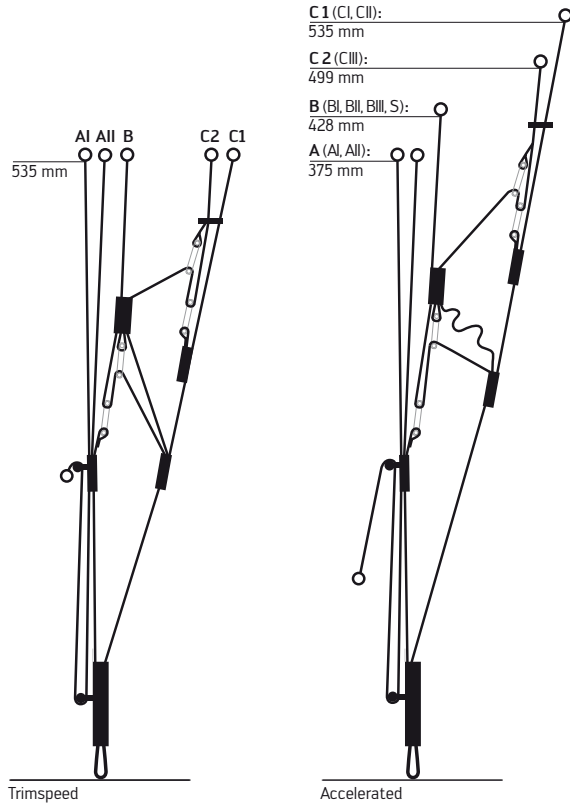

17 OVERVIEW GLIDER

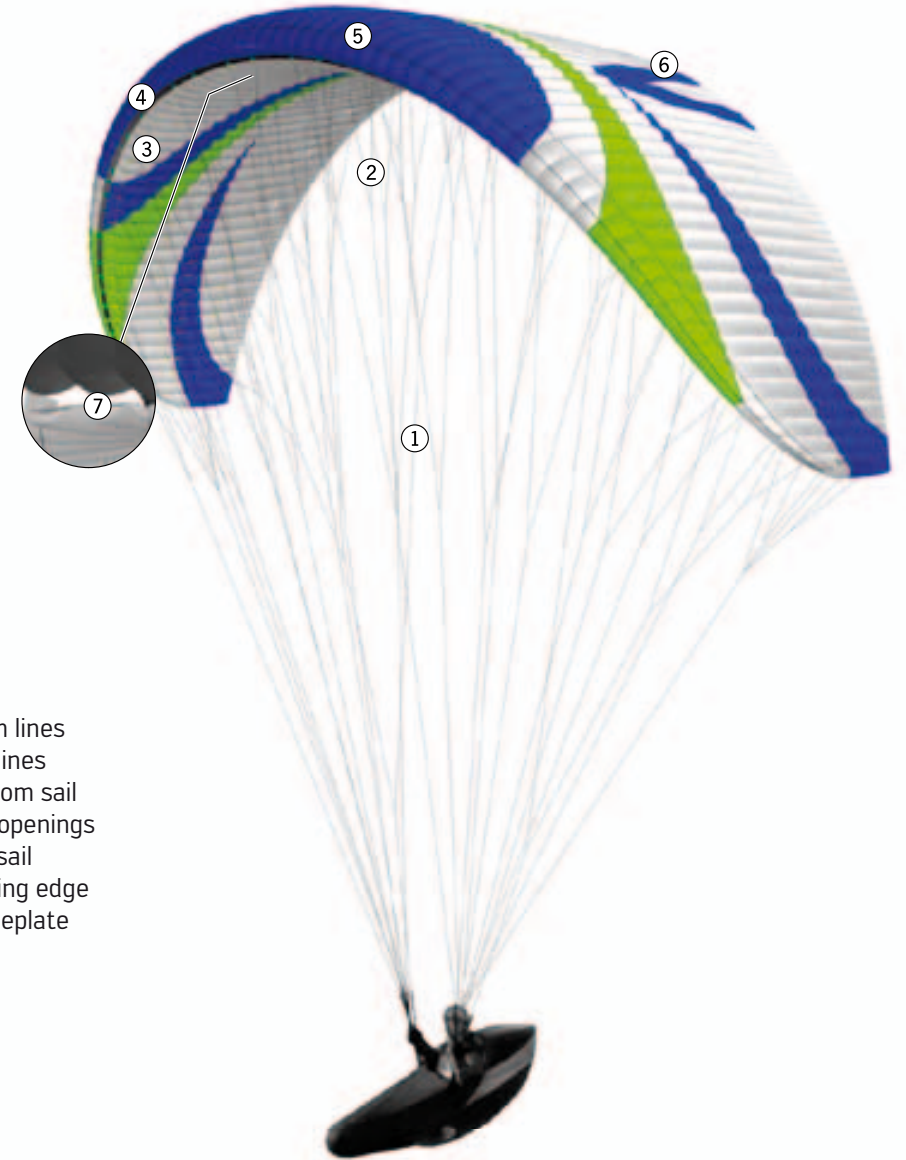

Test Protocol			Date:
Customer, Name:			
Adress:		Phone:	
Glider:	Size:	Serial number:	
GütesiegeInr.:		Date of last check:	
Date of first flight:		Year of construction:	

Accomplished checking:	Results [+/-]:	Description of failure:	Suggested repairs:
Identification:	<input type="checkbox"/> + <input type="checkbox"/> -		
Visual check of canopy:			
Upper surface:	<input type="checkbox"/> + <input type="checkbox"/> -		
Lower surface:	<input type="checkbox"/> + <input type="checkbox"/> -		
Profiles:	<input type="checkbox"/> + <input type="checkbox"/> -		
Line flares:	<input type="checkbox"/> + <input type="checkbox"/> -		
Leading edge:	<input type="checkbox"/> + <input type="checkbox"/> -		
Trailing edge:	<input type="checkbox"/> + <input type="checkbox"/> -		
Crossports:	<input type="checkbox"/> + <input type="checkbox"/> -		
Visual check of lines:			
Seams:	<input type="checkbox"/> + <input type="checkbox"/> -		
Abrasion spots:	<input type="checkbox"/> + <input type="checkbox"/> -		
Core withdrawals:	<input type="checkbox"/> + <input type="checkbox"/> -		
Vis. check of connection-parts:			
Suspension line screw locks:	<input type="checkbox"/> + <input type="checkbox"/> -		
Risers:	<input type="checkbox"/> + <input type="checkbox"/> -		
Length measurement:			
Risers:	<input type="checkbox"/> + <input type="checkbox"/> -		
Lines:	<input type="checkbox"/> + <input type="checkbox"/> -		
Examinations of the canopy:			
Firmness of canopy:	<input type="checkbox"/> + <input type="checkbox"/> -		
Porosity:	<input type="checkbox"/> + <input type="checkbox"/> -		

Examinations of the lines:			
Firmness of main lines:	<input type="checkbox"/>	<input type="checkbox"/>	<input type="checkbox"/>
	<input type="checkbox"/>	<input type="checkbox"/>	<input type="checkbox"/>
	<input type="checkbox"/>	<input type="checkbox"/>	<input type="checkbox"/>
Visual check of trimming:			
Checkflight necessary?			
Gütesiegel patch?			
Identification plate?			
Condition:	<input type="checkbox"/> New <input type="checkbox"/> Very good condition <input type="checkbox"/> Good condition <input type="checkbox"/> Well used <input type="checkbox"/> Heavily used, but within gütesiegel standards, frequent checks required <input type="checkbox"/> no longer airworthy, outside of the limit values.		
Repairs made?:			
Signature of tester:		Date:	
Name of tester:		Firm stamp:	

skywalk GmbH & Co KG

Windeckstr. 4 | 83250 Ma. rquartstein | +49 (0) 8641/69 48 40 | info@skywalk.info | www.skywalk.info

